



**SOLBERG**

*Discover the Possibilities*

*[www.solbergmfg.com](http://www.solbergmfg.com)*



**Filters • Silencers • Air / Oil Separators  
Separators • Vacuum Filters • Silencer Base Frames**

**S**ince 1968, Solberg Manufacturing, Inc. has been providing filtration solutions to our customers. We provide a wide range of products from inlet filters, silencer filters, oil mist exhaust filters and air/oil separators. Because every application is unique we offer industrial, severe and extreme duty models. This assures efficient filtration over a wide range of environments and conditions. Solberg has always believed in maintaining a **Large Inventory** of ready to ship filters and elements so our customer's needs are taken care of first and foremost. Visit Solberg on the web at [www.solbergmfg.com](http://www.solbergmfg.com). If you want to **Order Online** easily and quickly or have our complete catalog immediately or simply look at application photos, [www.solbergmfg.com](http://www.solbergmfg.com) has it for you. The website is continually updated to better provide you with the tools you need.

Our company, above all else believes that when we are taking care of our customers, we are taking care of ourselves. Our entire company revolves around this belief. Our people are at the core of our business and with them we bring to our customers a highly qualified and motivated staff. Together, we have succeeded in building a solid foundation, enabling us to serve our customers with dependable products and grow into the future.



## Manufacturing/Production

To provide quick response to your needs, we maintain a wide range of **Ready to Ship** assemblies and elements. The majority of orders received ship the same day. Solberg also has stock quantities on many stainless steel filters, filter silencers and elements. We designed our manufacturing and warehousing facilities to handle both large volume orders and low quantity specialty runs with the same quality and expertise you have come to expect. Solberg's **Quality** and **Expertise** have remained constant in all that we do. It is shown in our materials, our machinery, our products and most of all in our customers.





## Sales/Customer Service

Our sales group is committed to offering **Superior Service** and **Quick Response** at all times. They go through intensive training to understand each step of the production and sales process. They are required to have an in-depth knowledge of our products and receive continual training so you receive the information you need, quickly and accurately. Our Sales and Customer Service personnel are ready to assist you and all your filtration needs.

## Engineering

Solberg's engineering department's goal is to provide filtration solutions that separate you from the rest. Our experience enables us to provide answers you can **Trust** and depend on. The Solberg Engineering Lab is at the forefront of filtration technology. We feature state-of-the-art equipment for precise measurements and testing facilities that attain real life conditions. Our dedication to R & D has remained the focal point in everything we do. We provide you with **Solutions** you can use and trust.



# FILTERS/SILENCERS

Industrial & Severe Duty • Compressors • Blowers •  
Hydraulic Breathers • Engines • Pneumatic Conveying • Fans



## 1:1 MINATURE PATENTED FILTER SILENCERS

FS Series – PS Series: Up to 35 SCFM

- **Patented** high-grade element w/built-in vacuum tight seal
- FS Series – Seamless drawn housings-no welds to rust or vibrate apart
- PS Series – Plastic housings for light duty applications

Ask for Bulletin SF



## 1:3 COMPACT & BIG BOY FILTER SILENCERS

FS Series: Up to 8000 SCFM

- Tubular silencing design offers silencing with minimal space requirements and minimal pressure drop
- Multiple element sizes per connection for different severity levels
- Stainless steel and epoxy coated housings available. Contact factory for more information.
- For larger air flows use our Mega Boy or Multibarrel Series

Ask for Bulletin SF



## 1:4 PREMIUM GRADE SILENCER FILTERS FOR BLOWER INDUSTRY

2G Series

### Reduce Footprint and Costs, Direct & Indirect

- Overall Cost of assembling a blower package is Dramatically Lowered
- Power consumption (amp draw) is reduced allowing for increased performance and lower pressure drop
- The number of costly components in a system are reduced, **Shrinking the Footprint.**

Ask for Bulletin SF

## 1:5 REVOLUTIONARY COMPACT BLOWER BASE FRAME w/INTEGRATED DISCHARGE SILENCER

BBF Series

- Radically changes the way blower packages are built with a compact and cost effective frame
- Significantly lowers your cost with easy assembly (only 1 wrench required), complete hardware is included, & minimal components needed
- Compact design allows you to build your sound enclosure competitively

Ask for Bulletin BPDBI



## 1:2 SMALL COMPACT FILTER SILENCERS

FS Series - QB Series: Up to 300 SCFM

- Tubular silencing design maximizes attenuation and minimizes pressure drop
- **Seamless drawn housings**
- QB Series has reinforced housings for increased sound suppression

Ask for Bulletin SF



## 1:7 COMPACT & BIG BOY FILTER ASSEMBLIES

F Series: Up to 8000 SCFM

- All housings constructed for rugged conditions
- Multiple element sizes per connection for different severity levels
- **Stainless steel** and **epoxy coated** housings available. Contact factory for more information.
- Extreme duty SpinMeister option available on selected models
- For larger air flows use our Mega Boy or Multibarrel Series

Ask for Bulletin FA



## 1:8 EXPOSED ELEMENT FILTER ASSEMBLIES

FT Series: 7 to 8000 SCFM

- Ideal for space restricted environments and very low pressure drop applications
- Multiple element sizes per connection for different severity levels
- Stainless steel and epoxy coated housings available. Contact factory for more information.

Ask for Bulletin FA



## 1:9 ABSORPTIVE SILENCERS For Air Intake & Discharge

SLCR Series

- Layered sound absorbent media
- Minimal pressure drop design
- Available in FPT and MPT connections
- Maximum temperature of 212°F (100°C)

Ask for Bulletin SF



### 1:6 SMALL COMPACT FILTER ASSEMBLIES

F Series: Up to 300 SCFM

- Compact design for minimal footprint
- **Seamless drawn housings**-no welds to rust or vibrate apart
- Low pressure drop design
- Extreme duty SpinMeister™ option available on selected models

Ask for Bulletin FA

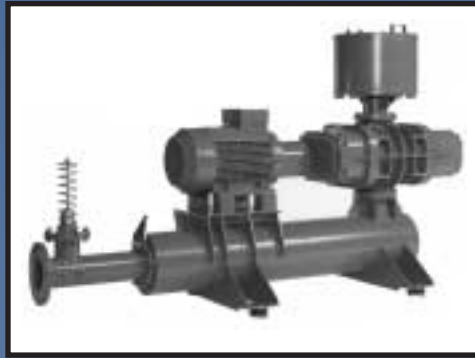

Filter Silencer on a Direct Drive PD Blower

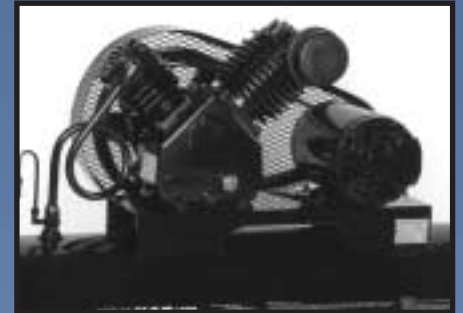

FS Series Small Patented Filter Silencer for Piston Air Compressor



MBF Series Multibarrel Filter Silencer for Blower Inlet



### 1:10 LATERAL ACCESS SILENCER FILTERS

LQB Series

- Side access door allows for easy side servicing and reduced servicing height requirements
- Compact housing makes enclosures feasible
- Differentiate your blower package

Ask for Datasheet LQB

(To reduce your footprint even further contact Solberg about the **BBF Series, Compact Blower Base Frame Series.**)

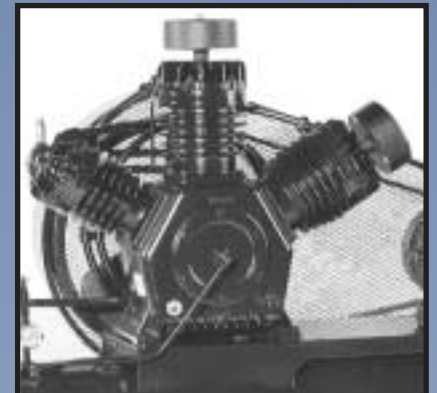

Compact Filter Silencer on 2 Stage Piston Compressor



Lateral Access "LQB" Silencer Filter within a Compact Blower Enclosure



## 2:1 "L" STYLE INLET VACUUM FILTERS

CSL Compact Series: 18 to 300 SCFM

- Seamless drawn housings-no welds to rust or vibrate apart
  - Positive engagement O-ring seal system
  - Easy access with "L" configuration
  - Brazed fittings for High vacuum duty
- CSL Midsize/Large Series: 300 to 4950 SCFM
- Heavy duty T bolts and durable carbon steel construction
  - Positive engagement O-ring seal system
  - Multiple element sizes per connection for different severity levels
  - Stainless steel and epoxy coated housings available

Ask for Bulletin VF



## 2:2 "T" STYLE COMPACT VACUUM FILTERS

CT Series: 175 to 1100 SCFM

- "T" style design Minimizes piping requirements
  - Cast aluminum top (resists corrosion) with machined connections has an Integrated Baffle design
  - **See-Through Buckets for 3" and 4" Sizes**
  - Inlet is above the element to Extend element life and maintenance intervals
  - Extreme duty SpinMeister™ option available
- Ask for Bulletin VF



## 2:3 INLET VACUUM FILTERS

VS Series • VL Series

- Compact design for space restricted areas
- Quick release "V" band clamp
- Built-In Baffle
- Both "Straight Through" and "L" designs available
- Stainless steel and epoxy coated housings optional

Ask for Bulletin VF



## 2:4 INTEGRATED LIQUID SEPARATOR / VACUUM FILTER

LRS Series

- Simplify vacuum pump package by integrating the liquid separator and the inlet vacuum filter
- Protect pump from harmful liquids
- Reduced parts and piping lowers costs
- High efficiency separation
- Configured product for easy modification
- Multiple options and configurations
- Available in epoxy coated carbon steel or stainless steel

Ask for Bulletin VF



ST-SpinMeister™ Combo with See-Through Housings used for Extremely Dirty Applications on a Multi-Stage Side Channel Vacuum Pump



Stainless Steel VS Series Vacuum Filter on Blower for Sensitive Cargo



CSL Vacuum Filter With Special RMS Finish on a Rotary Vane Vacuum Pump

# 3

## OIL MIST EXHAUST FILTERS

Vacuum Pumps & Systems • Food Processing & Packaging • Industrial Vacuum Processes • Medical Industry • Oil removal • Blower exhaust oil mist removal



### 3:1 HEAVY DUTY OIL MIST EXHAUST FILTERS

HDL Compact Series: 40 to 250 SCFM

- Minimum 99.97% D.O.P. on 0.3 microns
- Captures oil fog, mist or smoke from exhaust of oil flooded vacuum pumps
- Seamless drawn housings-no welds to rust or vibrate apart
- Positive engagement O-ring seal system
- Easy access with "L" configuration

HDL Midsize/Large Series: 300 to 1800 SCFM

- Heavy duty T bolts and durable carbon steel construction
- Large oil holding capacity
- Multiple separation stages in single element design

Ask for Bulletin AO



HDL Series Heavy Duty Exhaust Filter on Rotary Vane Vacuum Pump



Severe Duty Exhaust Filter on Vacuum Pump



Compact Oil Mist Exhaust Filter Mounted on a Vacuum Pump

### 3:2 OIL MIST EXHAUST ELIMINATORS

EE Series • EF Series • EFDB Series

- Minimum 99.97% D.O.P. on 0.3 microns
- Compact, low profile design utilizing high performance coalescing media
- Seamless drawn housings

EE Series

- Back pressure valve for pump safety
- 1/8" oil drain for oil recycling

EF Series

- Easy thumbscrew access
- Steel construction with plated finish

EFDB Series: Auto Drain Back

- Internal drain returns oil back in pump
- Prevents oil blow back with auto sealing

Ask for Bulletin AO



### 3:4 SPIN ON AIR/OIL SEPARATORS

- In-line separator elements for air/oil separation on rotary and piston compressors
- Imprinting and blind units available
- Heads and adapters available
- Oil filters – contact factory for more information
- Contact Solberg for custom applications

Ask for Bulletin AO or Datasheet LG



### 3:3 AIR/OIL VACUUM PUMP SEPARATOR

- COMPLETE separator package for vacuum pumps (No need for other separator hardware.)
- Simplifies system package by integrating sump tank with separator
- Multiple separation stages

Ask for Bulletin AO



### 3:5 "TOP HAT" AIR/OIL SEPARATOR ELEMENTS

- Multiple media config. depending on applications
- Maintenance free
- Wide range of operation flows
- Designed for vacuum pumps (Oil Sealed Liquid Ring, Rotary Vane) and compressors (Rotary Screw, Rotary Vane, Rotary Piston)

Contact Solberg for more information

# 4

## SPECIAL APPLICATIONS



### 4:1 FILTER ELEMENTS

Various Media and Sizes

- Chemical Grade
- Coalescing
- High Temperature Resistant
- Stainless Steel construction
- Patented Element w/Multiple Configurations
- Inquires Encouraged

Ask for Bulletin EL



### 4:2 HYDRAULIC BREATHERS

Fine Filtration for Heavy & Severe Duty Systems

- High efficiency polyester filter media:  
99+% at 5 micron
- 1/4" MPT to 12" Flange
- Up to 35250 GPM

Ask for Bulletin SP or Datasheet HB



### 4:3 EXTREME DUTY FILTERS

SpinMeister™ Filters for both pressure and vacuum applications

- Offers extreme duty filtration for harsher highly dirty environments when combined with a Solberg filter.
- Significantly increases the service life of your filter
- Reduce service costs and replacement element costs

For Pressure Systems ask for Bulletin FA or Datasheet SM13

For Vacuum Systems ask for Bulletin VF or Datasheet SM23

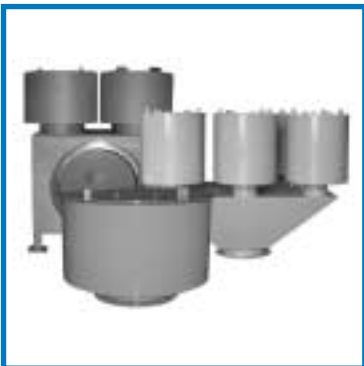

### 4:4 LARGE AIRFLOW APPLICATIONS

MBF Series – Multibarrel Filters

- Up to 24" flange & 25000 SCFM
- Trapezoid or box manifold base

Mega Boy Series

- Single Barrel Filter Design
- Up to 8000 SCFM

Ask for Bulletin SP



**A**s founder of a manufacturing business, I am often asked, “What caused you to start your own business?” In brief, my sales oriented life had never quite satisfied my self-reliant nature. Although I had never sold air filters, my sales of electric motors led me to the Air Compressor and Blower markets. From sales calls on my compressor accounts, I recognized the need for an inlet filter with a lower pressure drop and better silencing. I made my first prototype in 1966 and was pleased by the positive response I received. Due to a bit of creativity and a bit of luck, the air compressor market had its first tubular Filter Silencer. Since then, my first design has been steadily improved over the years.

Today, we manufacture a dependable and well-designed product, which allows us to reinvest in our people and our facilities. Our employees and our suppliers are exceptional and provide our competitive edge in all that we provide. We hope that your association with us will give you the confidence to rely on us for all your filter/silencer requirements.

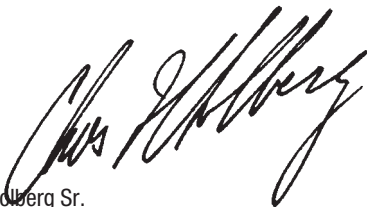

Charlie Solberg Sr.  
Founder of Solberg Manufacturing, Inc



*Discover the Possibilities*

Visit the perfect online tool  
for your filtration needs  
***WWW.SOLBERGMFG.COM***

Contact Solberg for the  
representative nearest you.



Solberg Manufacturing, Inc.  
1151 Ardmore Avenue  
Itasca, IL. 60143 USA  
Sales/Service: 630.773.1363  
Office: 630.616.4400  
Fax: 630.773.0727  
E-mail: sales@solbergmfg.com